

PERSPECTIVES OF USING ELECTROMECHANICAL TRANSMISSIONS IN AGRICULTURAL TRACTORS AND SELF-PROPELLED MACHINES

**Simion POPESCU, Ph.D, Professor
Dan CIOROIANU, Eng., Ph.D Student,
Vlad POPESCU, Ph.D, Lecturer
Transilvania University of Braşov, Romania**

Rezumat. În lucrare sunt prezentate și analizate posibilitățile de introducere a transmisiilor electromecanice la tractoarele agricole și mașini agricole autopropulsate, având în vedere realizările obținute până în prezent pe plan mondial. Se prezintă scheme structurale și cinematice de transmisii electromecanice și se face o comparație între transmisiile mecanice, hidrostatice și electromecanice sub aspect tehnic și economic.

Cuvinte cheie: tractoare, combine de cereale, transmisiile electromecanice, randamente transmisie

1. INTRODUCTION

The electromechanical transmission using on agricultural tractors represent a potential of innovation and theoretical and experimental research for products releasing with a higher functional and energetic parameters. In the last ten years the performances of the used electromechanical transmission on auto vehicles were continuous improved and their production costs were permanent less. Therefore, the changing of the actual mechanical or hydro-mechanical transmission with electromechanical one represents the tendency, which has to concerning of manufacturer of tractors and auto propelled machines (self-propelled combine).

In the last years appeared few of the base solutions of the electromechanical transmission and a raw of their variants. From the done analyses over the achievements and research on the international plan lead toward a tendency of continuous reducing of the production costs of the electromechanical transmission face to the electromechanical transmission of the tractors, tracks and cars (fig.1). The reason of the production costs reducing explain through the price reducing of the electrical and electronic products, through the synergic effect released through the new tendencies from mechatronic and through the simplicity of mounting technology. The eventually disadvantages which appear through the increasing of the necessary volume to fit the components on the vehicle and through the increasing in a some

measure of the constructive weight, do not play a major role in case of tractors and agricultural machineries.

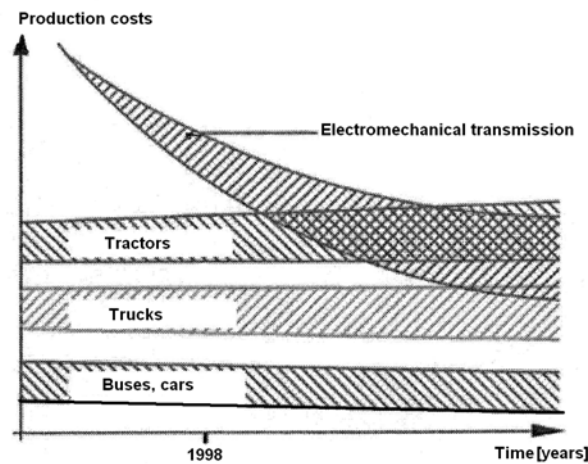

Fig.1. Cost evolution of electromechanical transmission on comparison with the mechanical transmission of different self-propelled vehicles[4]

The use of electromechanical transmissions at agricultural tractors and auto propelled machines are made from the direct and indirect coupling of two electrical machines: the electrical generator, that assure the conversion of received mechanical energy from the auto-vehicle engine in electrical energy, and the electrical motor (electrical motors), that convert the received electrical energy from the generator in mechanical power, which it send to a mechanical transmission of the lead wheels. After the transmission way of the mechanical power from the diesel engine to the driven wheel of the self propelled vehicle, the electromechanical transmission can be: a)- with a single power flow (in series) and b)- with two power flow (named divided transmission or in parallel).

The base configuration of an electromechanical transmission with a single power flow is presented in the figure 2. The necessary power for the driven axle 5 is taken from the diesel engine 1 through the electrical generator from the rotary current. The supplied current by generator is rectified into direct current through the current rectifier 11, after which it is transformed again, through inverter and a frequency converter in a rotary current with variable voltage, strength and frequency. This current then drives an electric motor 3, which in turn is connected with a conventional final drive. The operation of the drive and the choice of the individual transmission strategy are carried out using a hand lever 8 or foot pedal 7 as well as

via a user terminal 10. The mechanical transmission of the power take-off shaft 4 receives the driving from the generator shaft 2 (coupled with the Diesel engine 1), the speed of the take-off shaft (PTO) being on concordance with the tractor engine speed.

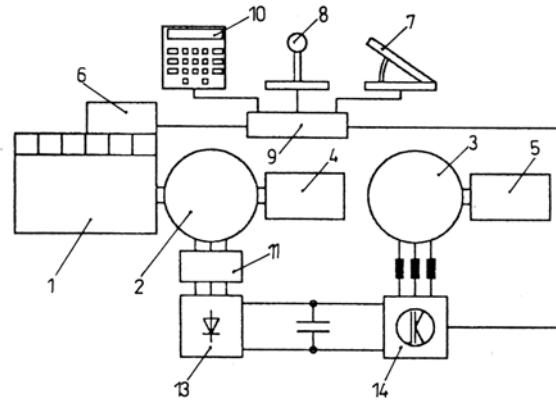

Fig. 2. The principle diagram of an electro mechanical transmission with a power flow [6]:
 1-engine with internal combustion (diesel engine); 2- electrical generator; 3-driven electrical motor; 4-take-off shaft(PTO) transmission; 5- driven axle of self propelled vehicle; 6- injection system of diesel motor; 7-speed lever of motor; 8- hand lever; 9- control unit; 10-user terminal; 11-network filter; 13-rectifier; 14-inverter.

At the use of the electromechanical transmission to the combine harvester (Fig. 3) are used compact generators and motors for the high power, with a double-circuit cooling system.

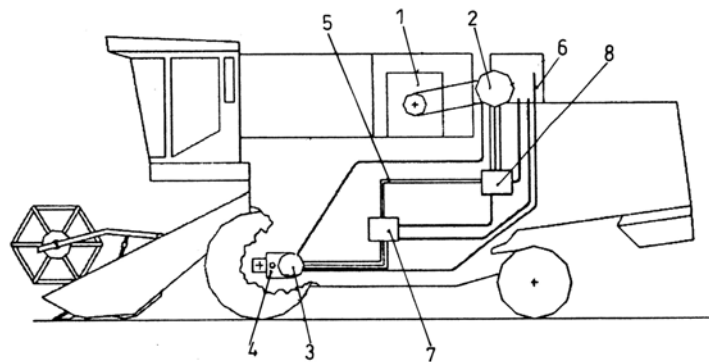

Fig. 3. The set up diagram for the electromechanical transmission components with a power flow in the case of the self propelled combine harvester [2;3]:
 1- Diesel engine; 2- synchronous electrical generator; 3- driven electrical motor (asynchronous); 4- gear box; 5- power circuit (DC); 6- cooling system; 7- motor inverter module; 8- generator inverter module.

The synchronous generator 2 (with permanent magnets) is driven by the diesel engine 1, via V-belts, and through the electrical circuit 5 supply the electrical energy for the driving of the electrical motor 3. The power of the rotary current generator 2 is controlled by generator inverter module (GIM) 8, which charges the main DC power

circuit 5 with an average of 650 V. The power from the DC power circuit is transferred into a rotary current again by the motor inverter module (MIM), which controls the power out put of the asynchronous driven motor and its rotational speed of up to 600 rpm. By installing an asynchronous motor and a slower running, more efficient but more expensive solution, the performances of the both electrical machines (generator and motor) can be improved.

In the figure 4 it is represent the cinematic diagram of an electromechanical transmission with a power flow, used at the tractor with an integral transmission (4X4). The diesel engine drives two generators: the DC generator 2 and the AC generator 3. The direct current supplies by the generator 2 drives the electrical motors 4, which drives independent the four driven wheels 10 of the tractor. The AC current from the generator 3 it is used for the feeding of the asynchronous electrical motors 5, and with their help is driven the direction mechanisms 6 of the two axles, and the electrical motor 7 of the cable roller. The electrical motors 4, drives the torque to the driven wheels 10 through the final transmission 9. The speed control and the change of the moving sense of the auto vehicle are realized with the help of the control and checking block. The diesel motor 1 of the tractor and the both generator 2 and 3 are fitted in the same block, making a compact construction.

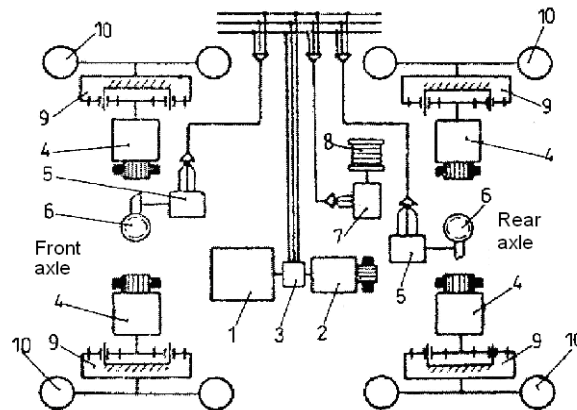

Fig. 4. The principle diagram of an electromechanical transmission with a power flow used at a integral transmission tractor (4x4) [5]

The transmission with the two power flows (divided transmission) is made from two distinct transmission (two power flows) coupled in parallel; one electrical transmission (electrical generator and motor) and one mechanical transmission. The same transmission limited the replacement possibilities of the electrical and

mechanical components, but in the same functionally domain they achieve higher ratios than the transmission with a single power flow. On depending of the replacement way of the electrical transmission face to mechanical transmission, the transmission with a divided flow of energy can be grouped in two models: a)- with the electrical transmission placement at in and b)- with the coupling of electrical transmission of the out of the mechanical transmission (Fig. 5). These types of transmission need the use of some gearbox for the achievement of the needed vehicles speed domains.

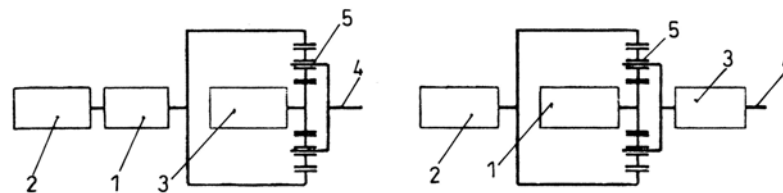

Fig. 5. The structural diagrams of the divided electromechanical transmission: with the electrical transmission placed at in (left) and with the electrical transmission placed at out (right): 1- Diesel engine; 2- electrical generator; 3- electrical motor; 4-current converter (rectifier); 5- output of transmission; 6- planetary gear.

The ratio, which has the supplied power on the electrical way over the driven effective power realized by the tractor, is on concordance with the tractor speed. In the figure 6, are represented the typically modify curves of the electrical power ratio face to the driven total power in the situation which the diesel engine functions with constant speed.

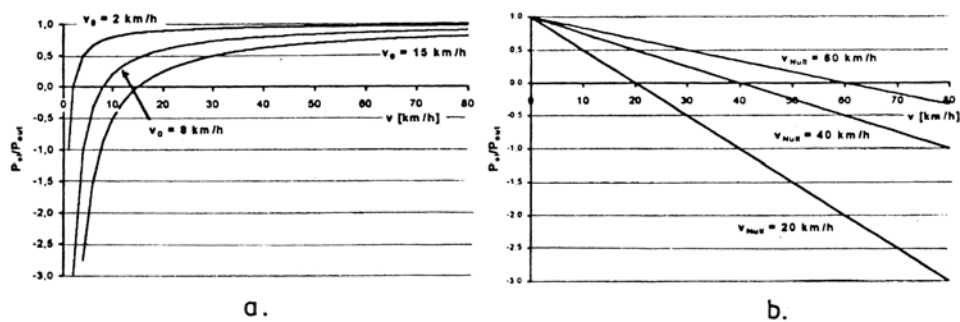

Fig. 6. The electromechanical transmission power ratio over the driven effective power realized by tractor: a-with electrical transmission placed at in; b- with electrical transmission placed at out.

In the case of the electromechanical transmission coupling at in (Fig. 6, a) at the tractor displacement with slow speeds in the transmission appear parasite power flows (which can be seeing on the diagram through the negative value of the

electrical power ratio). In the case of the transmission at output (Fig. 6, b), the whole power is sent through the electrical transmission, so at the starting of the whole necessary torque is getting from the electrical motor

In the future the possibilities of the power continuous modifying in electromechanical transmission will lead to increasing of working machineries productivity and the simplicity of the execution of the technological operation. The power electromechanical transmission will increase in importance as an alternative at the hydrostatic transmission. The work of the driver will be reduced to the minimum, and the productivity will increase due the speed increasing and time expending of the machinery work in the nighttime. After what it will be solved a series of safety problem of displacement, then there will be used self propelled vehicle fit up with electromechanical transmission, which at beginning will be restriction at the simple working execution under human control and driving. The vehicle automat control, especially through the position increasing of the global position system (GPS), will allow working technologies without driver. At industrial vehicle, as are forklifts and tracks, the electromechanical transmission using increased instead of those hydrostatic.

References

- [1]. **Barucki, T.** *Realisierungsmöglichkeiten elektrischer Traktorantriebe. Landtechnik, 1999, H. 4, S. 228-229.*
- [2]. **Bernard, B. Kutzbach, H. D.** *Serial Hybrid Electric Drive Train for a Combine Harvester, Paper Nr. 02-PM-023. AgEng, Budapest, 2002.*
- [3]. **Kutzbach, H.D.** *Trends in Power and Machinery. J. Agric. Engng. Research 76 (2000), H. 3, S.237-247.*
- [4]. **Harms H.-H.** *Elektrische oder hydraulische Antriebe in der Landtechnik. VDI-MEG Tagung Landtechnik, 1998, VDI Berichte 1449,. S.61-63.*
- [5]. **Nitescu, G. Nastasoiu, S., Popescu, S.** *Tractoare, EDP, Bucuresti, 1974.*
- [6]. **Schmetz, R.** *Elektromechanische Traktorgetriebe. Landtechnik, 1999, H. 2, S. 72-73.*
- [7]. **Techmann, J.** *Möglichkeiten und Anforderungen elektromechanischer Antriebssysteme an mobilen Arbeitsmaschinen. VDI-Meg Tagung Landtechnik, 2002,, VDI Berichte 1716, S. 31-36, VDI-Verlag, Düsseldorf, 2002.*